

Paradox SP6000



PERMACONN™
leaders in wireless security technology

- ✓ **Keyswitch wiring**
- ✓ **Keyswitch programming**

Background: There are three (3) Outputs available.

- Outputs are 'Open Collector' @50mA switching negative - for heavier loads a relay must be used.
- Outputs can be used for e.g. Keyswitch, opening gates or doors etc.
- Ensure there is a common negative between Permaconn and the device being switched.
- The outputs can be Opened, Closed or Pulsed remotely using the Permaconn Atlas web portal.
- The Pocket Secure App can only 'Pulse' the Outputs. A Pulse is approx 1sec.



Compatible with 'Pocket Secure' remote arming App, available on iTunes, Google Play and the Windows Phone Store.

- These outputs when wired to a Keyswitch zone on the Alarm Panel can arm & disarm up to a maximum of three (3) areas when using 'Pocket Secure' app.
- Each area should be independently controlled using a separate Keyswitch zone.
- Arm/Disarm reporting **MUST be Enabled**. Pocket Secure App requires this for its status notifications.
- Test each Output by placing the +ve leg of a multi meter on the +ve terminal that supplies power to the Permaconn, then place the -ve leg of a multi meter on the Output terminal you wish to test. Pulse the selected Output the result should go from 0v DC to 12v DC for approx 1sec and back to 0vDC.

Paradox SP6000 Alarm Panel

If the Opening / Closing communicator codes are enabled, Key Switch arming/ disarming will report.

(Required for Pocket Secure App)

E.g. 1: Using zones 1 – 2 (DO NOT zone double Keyswitch zone).

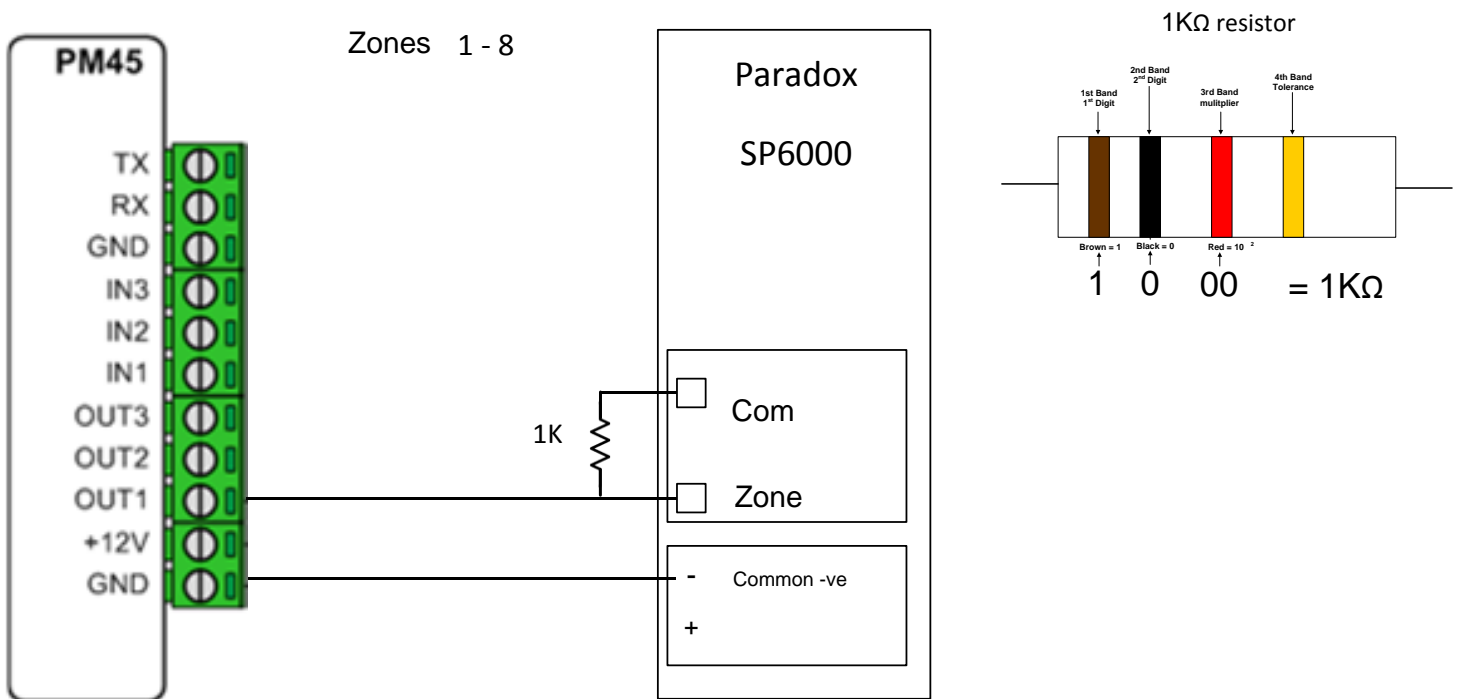

Programming A Paradox SP6000 for Keyswitch:

Section (001) = Zone 1
Section (002) = Zone 2
Section (003) = Zone 3
Section (004) = Zone 4
Section (005) = Zone 5
Section (006) = Zone 6
Section (007) = Zone 7
Section (008) = Zone 8

Zone Definition: Must be set to '26'
(Keyswitch Momentary)

Partition Assignment:

Partition 1 = 1
Partition 2 = 2
Partition 1 & 2 = 3 (must be set for arming both partitions on 1 keyswitch zone)

Other Options:

Switch to Stay Arming if no Entry Delay is opened

Section [741]: = Partition 1
Section [742]: = Partition 2
Option [5] OFF = Switch to Stay Arming Disabled (default)
Option [5] ON = Switch to Stay Arming Enabled

If a user Regular arms a partition, but does not exit through (open and close) an entry delay zone during the exit delay, the control panel can be programmed to switch from Regular arming to Stay arming.

Regular Arming switches to Force Arming

(Not to be used with UL Installations)

Section [704]: Arming/Disarming Options
Option [1] OFF = Regular Arming Switches to Force Arming Disabled
Option [1] ON = Regular Arming Switches to Force Arming Enabled (default)

With this feature enabled, the control panel will always Force arm (if a force-enabled zone is open, see *Force Zones* on page 27) instead of Regular arm when a valid user access code with the Force Arming Option is entered.

Armed Report Delay

Section [851]
000 = disabled, 001 to 255 minutes, Default = 5 min.

The Armed Report Delay determines the amount of time after an Arming event that the control panel will wait before sending a report.

Disarmed Report Delay

Section [852]
000 = disabled, 001 to 255 minutes, Default = 60 min.

The Disarmed Report Delay determines the amount of time after an Disarming event that the control panel will wait before sending a report.

Report System Disarming

Section [801]: Arming /Disarming Options
Option [1] OFF = Always Report Disarming
Option [1] ON = Report Disarming Only After Alarm (default)

With option [1] OFF, the control panel will send the Disarming report codes (see *Special Disarming Report Codes* on page 43) to the monitoring station every time the system is disarmed. With option [1] ON, the control panel will send the Disarming report codes to the monitoring station when the system is disarmed following an alarm.

Reports as user 000, CID409 Keyswitch O / C